

RBC Bearings

LW Titanium Bearings

INTRODUCING

LW Titanium BEARINGS

by Schaublin

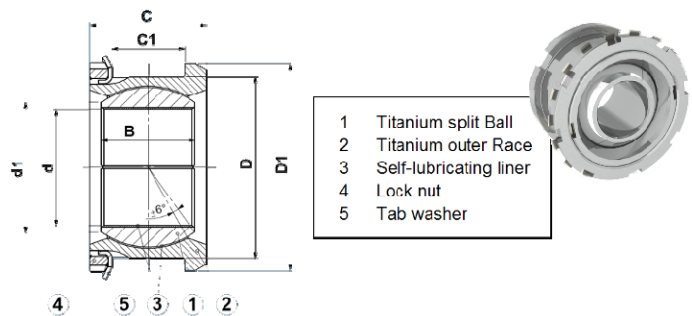

Background

- Schaublin has developed and produced a number of aircraft applications where weight savings was critical to the design.
- These bearings integrate structural components and provide complex configurations, like fork or eccentric designs to offer superior performance characteristics.
- These bearings are also used for dynamic applications where endurance and duty cycles are considered the most important function.

A Performance Solution

This new LW Titanium bearing product line uses self-lubricating technology, matching the Uniflon®-E PTFE liner with a titanium based advanced coating on the titanium ball surface resulting in extremely long life and low friction levels.

Duty cycles $\pm 5^\circ$, 120MPa, ball ϕ 77.9mm

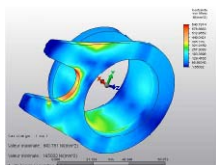
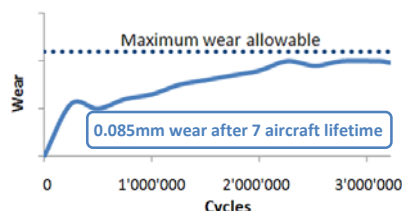

When needed, the complex outer race is designed and optimized using FEA (Finite Element Analysis).

RBC Schaublin Drw. #	d H7 [inch]	d1 [inch]	D [inch]	D1 [inch]	B [inch]	C [inch]	C1 [inch]	Nominal dynam. load (130 MPa) [lbf]	Weight Titanium [lb]	Weight SAVING vs. Steel [lb]
477-12012	1.000	1.186	1.625	1.938	0.813	1.000	0.563	15'827	0.293	0.227
477-12013	1.125	1.294	1.813	2.125	0.876	1.125	0.688	18'772	0.386	0.298
477-12014	1.250	1.436	2.000	2.250	1.000	1.250	0.813	24'527	0.503	0.388
477-12015	1.375	1.578	2.188	2.500	1.063	1.313	0.875	29'090	0.650	0.503
477-12016	1.500	1.762	2.375	2.625	1.188	1.500	1.000	34'059	0.818	0.632
477-12017	1.625	1.904	2.563	2.813	1.313	1.625	1.125	41'702	1.036	0.801
477-12018	1.750	1.969	2.688	3.000	1.438	1.813	1.313	48'828	1.221	0.944
477-12019	1.875	2.154	2.875	3.188	1.500	1.875	1.375	55'281	1.455	1.124
477-12020	2.000	2.296	3.125	3.438	1.586	2.000	1.438	61'980	1.867	1.443
477-12021	2.250	2.546	3.438	3.750	1.813	2.250	1.688	78'256	2.493	1.927

RBC Schaublin Drw. #	d H7 [mm]	d1 [mm]	D [mm]	D1 [mm]	B [mm]	C [mm]	C1 [mm]	Nominal dynam. load (130 MPa) [N]	Weight Titanium [gr]	Weight SAVING vs. Steel [gr]
477-12012	25.40	30.12	41.28	49.21	20.64	25.40	14.29	70'400	133	103
477-12013	28.58	32.86	46.04	53.98	22.25	28.58	17.46	83'500	175	135
477-12014	31.75	36.48	50.80	57.15	25.40	31.75	20.64	109'100	228	176
477-12015	34.93	40.07	55.56	63.50	26.99	33.34	22.23	129'400	295	228
477-12016	38.10	44.76	60.33	66.68	30.16	38.10	25.40	151'500	371	287
477-12017	41.28	48.36	65.09	71.44	33.34	41.28	28.58	185'500	470	363
477-12018	44.45	50.00	68.26	76.20	36.51	46.04	33.34	217'200	554	428
477-12019	47.63	54.72	73.03	80.96	38.10	47.63	34.93	245'900	660	510
477-12020	50.80	58.31	79.38	87.31	40.28	50.80	36.51	275'700	847	655
477-12021	57.15	64.66	87.31	95.25	46.04	57.15	42.87	348'100	1'131	874

Typical applications

- Wing/Pylon, Pylon/Engine attachment
- Flap beam
- Gear beam Torque Struts

Advantages

LW Titanium Bearings are proven and demonstrate very high performance.

- Qualified solution on existing aircraft programs
- Light Weight
- Titanium provides the best ratio of weight vs. strength
- Design can be made according to customer needs in either inch or hard metric dimensions

RBC Bearings

Innovation, Commitment, Quality

RBC has been producing bearings in the USA since 1919. In addition to unique custom bearings, RBC offers a full line of standard industrial and aerospace bearings, including:



Spherical Plain Bearings

Radial, angular contact, extended inner ring, high misalignment. **Quadlube®**, **ImpactTuff®**, **Spreadlock® Seal**, **CrossLube®**, **DuraLube™**, and self-lubricating bearing. Available in inch and metric sizes.



Needle Roller Bearings

Pitchlign® caged heavy duty needle roller bearing, inner rings, **TJ TandemRoller®** bearings for long life.



Thin Section Ball Bearings

Standard cross sections to one inch. Sizes to 40 inches. Stainless steel and other materials are available. Seals are available on all sizes and standard cross sections. Super duplex configurations.



Self-Lubricating Bearings

Radial, thrust, rod ends, spherical bearings, high temperature, high loads. Available in inch and metric sizes. **Fiberglide®** self-lubricating bearings



Tapered Roller Bearings

Tyson® case-hardened and through-hardened tapered roller bearings. Available in many sizes. Used in Class 8 heavy truck and trailer wheel bearings, gearboxes, and final drive transmissions.



Airframe Control Bearings

Ball bearing types, self-lubricating types, needle roller track rollers.



Tapered Roller Thrust Bearings

Case-hardened. Sealed and unsealed for truck, tractor, and construction equipment steer axles, and Class 8 trailer landing gear.



Dowel Pins, Loose Needle Rollers, Shafts

Precision Products dowel pins, loose needle rollers, and shafts.



Integrated Assemblies

For robots and other process tool applications. Engineering design assistance. Production volume capacity.



Commercial Rod Ends

Commercial and industrial, precision, Mil-Spec series, self-lubricating, and aircraft. Sold under the Heim®, Unibal®, and Spherco® names. Available in inch and metric sizes.



Cam Followers

Standard stud, heavy stud, yoke type, caged roller follower cam followers, Patented RBC Roller® cylindrical roller cam followers, HexLube® universal cam follower, airframe track rollers.



Ball Bearings

Precision ground, semiground, unground. High loads, long life, smooth operation. Nice® branded products are offered in caged and full complement configurations.



King pin Spherical Plain Bearings

Self-lubricating types, greased plain bearings, sealed. High loads, high vibration resistant, long life. **S-FIT™** and **CTRL™** configurations available.



Specials

RBC manufactures many specialty bearings for the aerospace, oil and energy, semiconductor equipment, packaging, transportation, and other industries.