

Douilles de réduction pour pinces
Reduktionshülsen für Spannzangen
Reduction sleeves for collets

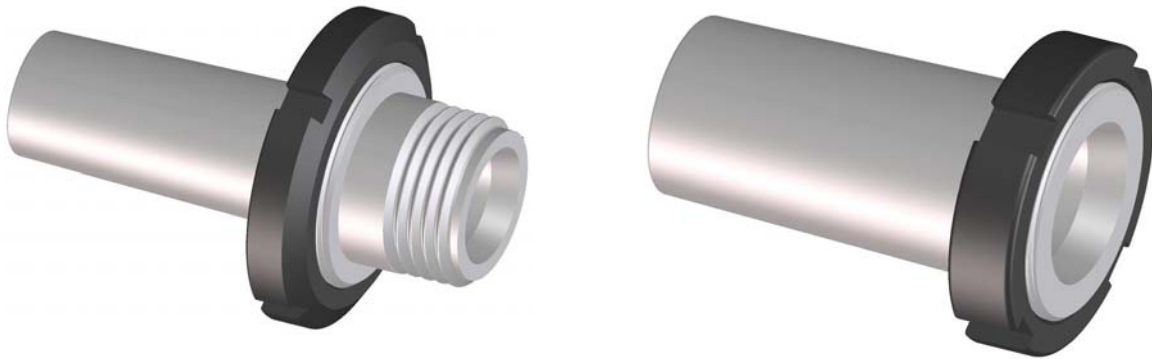

Les douilles de réduction sont destinées à pouvoir adapter les pinces les plus courantes sur n'importe quelle machine qui a une prise d'outil standard du type Morse.

Avec ces douilles vous pourrez serrer les pinces du type "W" et "B" (selon article) sur votre machine. De plus, si vous utilisez l'exécution avec un nez SCHAUBLIN (avec filet extérieur de même dimensions que les broches standards des tours SCHAUBLIN 102), vous aurez la possibilité d'utiliser aussi les accessoires et d'adapter les pinces entonnoirs ainsi que les tasseaux expansibles prévus pour le tour SCHAUBLIN 102.

Die Reduktionshülsen sind bestimmt für den Einsatz der gebräuchlichsten Spannzangen auf den verschiedensten Maschinen mit Standardaufnahmen oder Morsekegeln. Diese Hülsen ermöglichen den Einsatz von W- und B-Spannzangen auf der Maschine. Des weiteren lassen die Reduktionshülsen mit der Nase SCHAUBLIN (Aussengewinde und Abmessungen wie die Spindel Nase der Drehmaschine SCHAUBLIN 102) den Einsatz von Spreizdornen und Stufenzangen zu, was auf jeder Maschine die Spannmöglichkeiten vervielfacht.

The reduction sleeves are meant to adapt the most current collets on any type of machine with a Morse tool holding device. These sleeves will enable you to use collet types "W" or "B" (depending on the sleeve type) on your machine. In addition, if you use the version with a SCHAUBLIN nose (with external thread dimensionally identical to the standard SCHAUBLIN lathe spindles), you will be able to use the accessories as well, and adapt the internal stepped collets and expanding arbors to suit the SCHAUBLIN 102 lathe.

Douille de réduction Morse, nez SCHAUBLIN
Reduktionshülsen Morse, SCHAUBLIN Nase
Reduction sleeves Morse, SCHAUBLIN nose

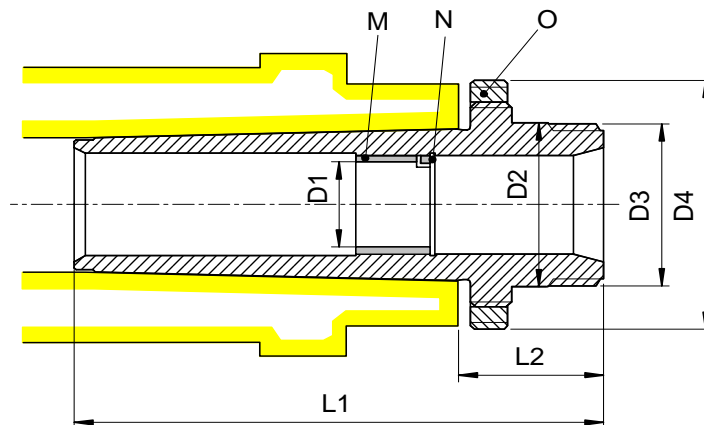

Ermöglicht den Einbau von Glockenzange, Ringfutter und Spreizdorne
 Permet l'emploi des pinces entonnoirs, pinces échelles et tasseaux expansibles
 Allows to use external step collets, internal step collets and expanding arbors

caractères gras : inclus dans la livraison
Fettschrift : im Lieferumfang inbegriffen
bold script : included in delivery

N		anneau Ring ring
O		écrou d'extraction Ausziehmutter releasing nut

Type	Art.	D1	D2	D3	D4	L1	L2	N	O
Mo4/W 20	68-03017	20	37.97	M37.6x3	75	100	38	102-21044	M387045
Mo5/W 20	68-03018 1)	20	37.97	M37.6x3	75	143	39.3	102-21044	M387045
Mo5/W 25	68-03019	25	48	M47.6x3	80	143	39.3	102-30005	M448060

1) Jusqu'à épuisement du stock
 Solange Vorrat
 Whilst stocks last

Douille de réduction Morse - Reduktionshülsen Morse - Reduction sleeves Morse

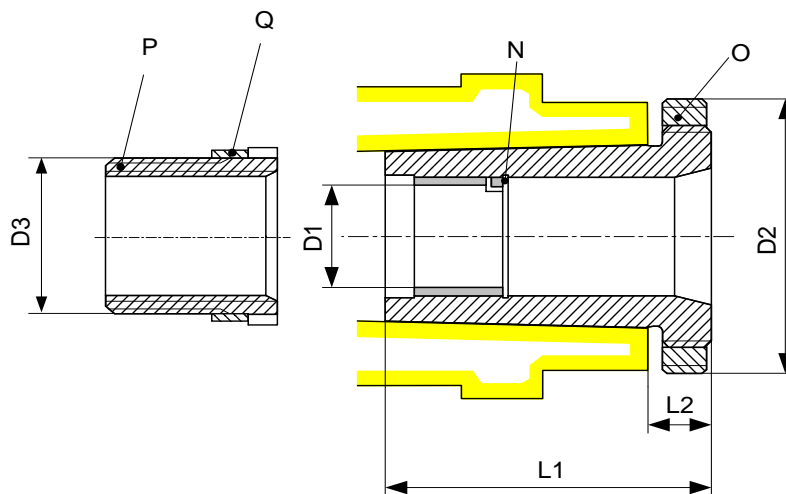

caractères gras : inclus dans la livraison
Fettschrift : im Lieferumfang inbegriffen
bold script : included in delivery

N		anneau Ring ring
O		écrou d'extraction Ausziehmutter releasing nut
P		écrou de réduction Reduktionsmutter reduction nut
Q		entretoise Distanzring spacing rings

Type	Art.	D1	D2	D3	L1	L2	N	O	P	Q
Mo4/W 20	12-01005	20	50	-	63	11	102-21044	12-01006	-	-
Mo4/W 25	68-03007 16)	25	50	-	67	23	-	12-01006	-	-
Mo5/B 32	150-21135	32	63	-	77	12	125-21024	160-21044	-	-
Mo5/W 20	150-20270	20	63	ø29.7 x15f"	75	12	102-21044	160-21044	160-20273	-
Mo5/W 25	150-20275	25	63	ø29.7 x15f"	68	12	102-30005	160-21044	160-20278	160-20279

16) Non applicable pour :
 Nicht geeignet für : 80-700 & 80-2006
 Non applicable for :

Douilles de réduction pour affûteuses Walter Helitronic Power et Mini Power
Reduktionshülsen für Schleifmaschinen Walter Helitronic Power und Mini Power
Reduction for grinding machines Walter Helitronic Power and Mini Power

Porte-pinces
Spannzangenhalter
Collet chuck

Type W20, W25

Fig. 1

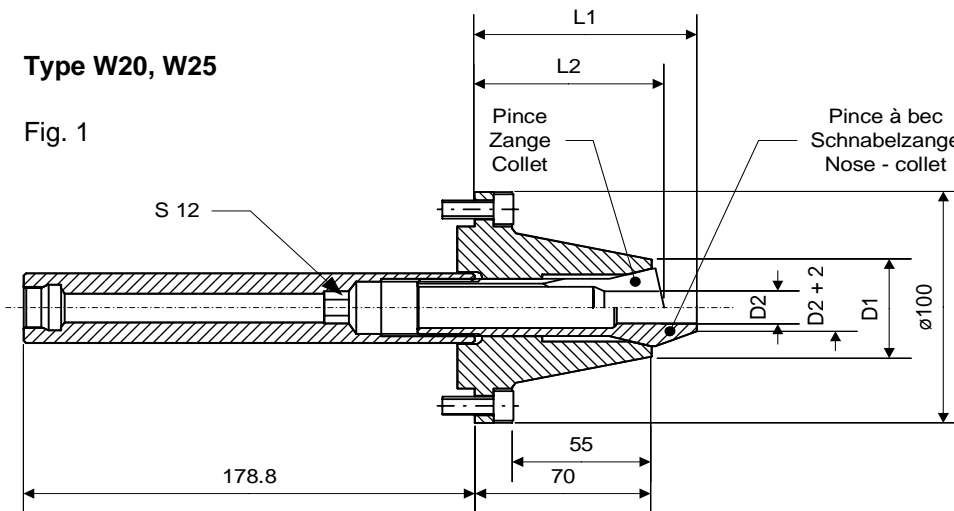
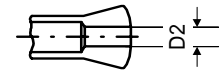

Fig. A

alésage outre
Durchgangsbohrung
through bore



Type B32/B45

Fig. 2

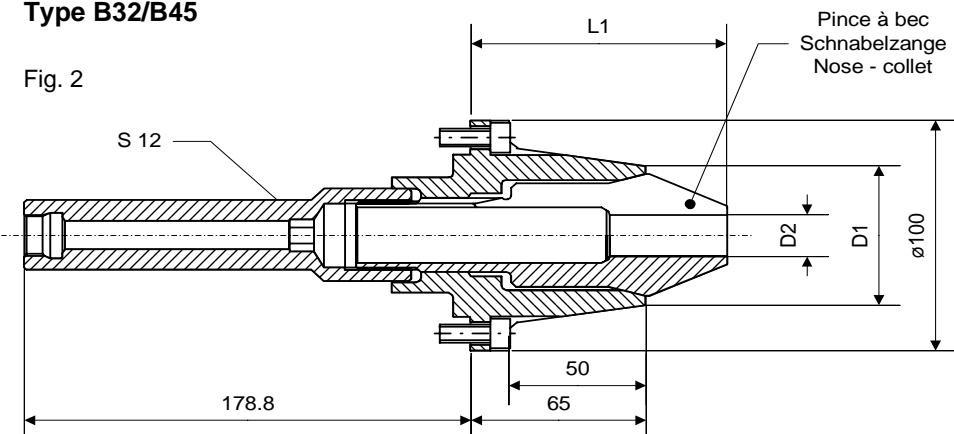
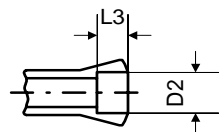

Fig. B

alésage à cran
Stufenbohrung
stepped bore



Type Typ Type	É. S.	Porte-pinces Sp.-zangenh. Collet chuck	D1	Pince Zange Collet	D2	L3 L2	Pince à bec Schnabelzange Nose - collet	D2	L3	L1	
W 20	1A	68-05128	32	80-00004	0.30...14.50	- 74	80-92744	0.30...13.00	-	85.5	
	1B					28			13.01...16.00		41
	1B					24			16.01...20.00		37
W 25	1A	68-05129	42	80-00005	0.30...19.05	- 75	80-92872	0.30...19.05	-	90	
	1B					35			19.06...21.00		50
	1B					30			21.01...25.40		47
B 32/45	2A	68-05130	59	-	-	-	72-02005	1.00...24.00	-	102.5	
	2B							24.01...40.00	80		

Douilles de réduction pour affûteuses Walter Helitronic Micro
Reduktionshülsen für Schleifmaschinen Walter Helitronic Micro
Reduction for grinding machines Walter Helitronic Micro

Porte-pinces
Spannzangenhalter
Collet chuck

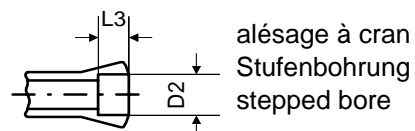
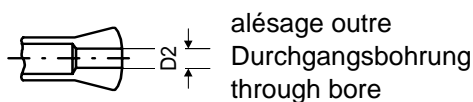
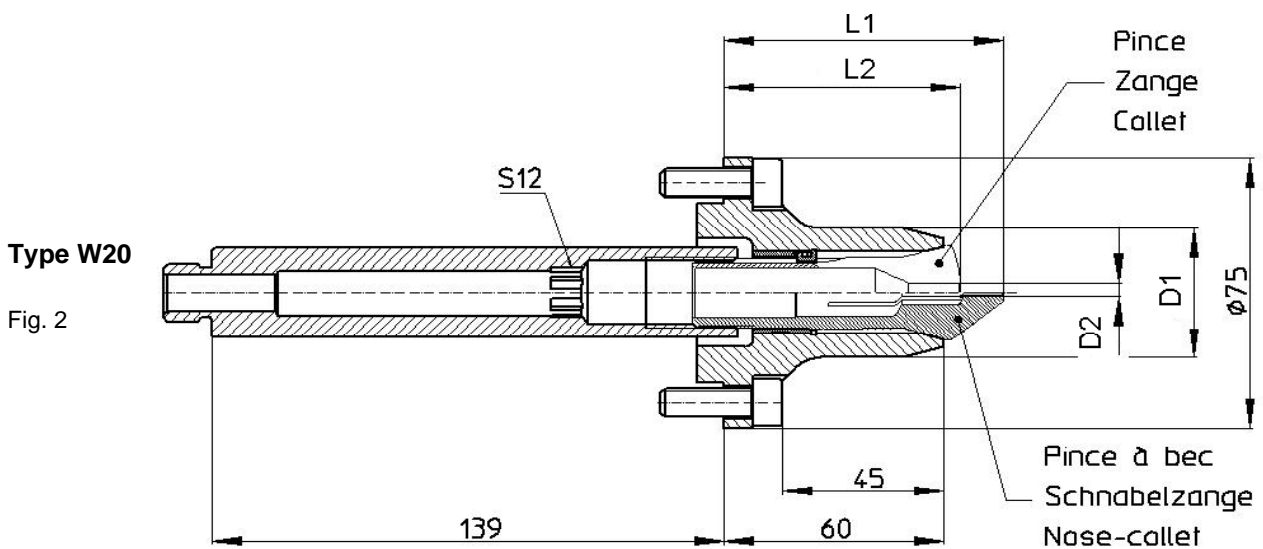
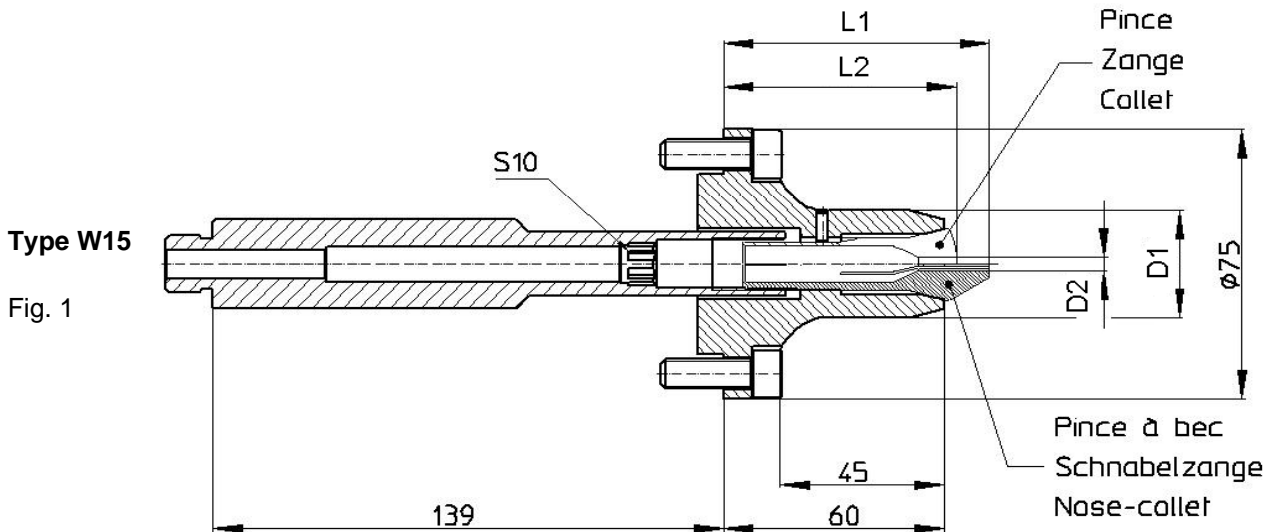

Type	Fig.	Porte-pinces Sp.-zangenh. Collet chuck	D1	Pince Zange Collet	D2	L3	L2	Pince à bec Schnabelzange Nose - collet	D2	L3	L1
W 15	1	68-05136	30	80-00003	0.30...10.70	-	63.5	80-93285	0.30...10.20	-	72.5
					10.71...12.70	22			10.21...12.70	32	
W 20	2	68-05137	30	80-00004	0.30...14.50	-	64.5	80-92744	0.30...13.00	-	76
					14.51...16.00	28			13.01...16.00	41	
				80-00107	16.01...20.00	24		80-93286	16.01...20.00	37	